

8

7

6

5

4

3

2

1

BOLLARD SELECTION

SELECTION	PART NUMBER	ABOVE GRADE HEIGHT (H)	MATERIAL	WEIGHT
	FB4F0830-F	30"	304 SS	110LBS
	FB4F0836-F	36"		124LBS
	FB4F0839-F	39.5"		133LBS
	FB4F0842-F	42"		139LBS
	FB6F0830-F	30"	316L SS	110LBS
	FB6F0836-F	36"		125LBS
	FB6F0839-F	39.5"		133LBS
	FB6F0842-F	42"		139LBS
	FBCF0830-F	30"	CARBON STEEL	107LBS
	FBCF0836-F	36"		121LBS
	FBCF0839-F	39.5"		129LBS
	FBCF0842-F	42"		135LBS

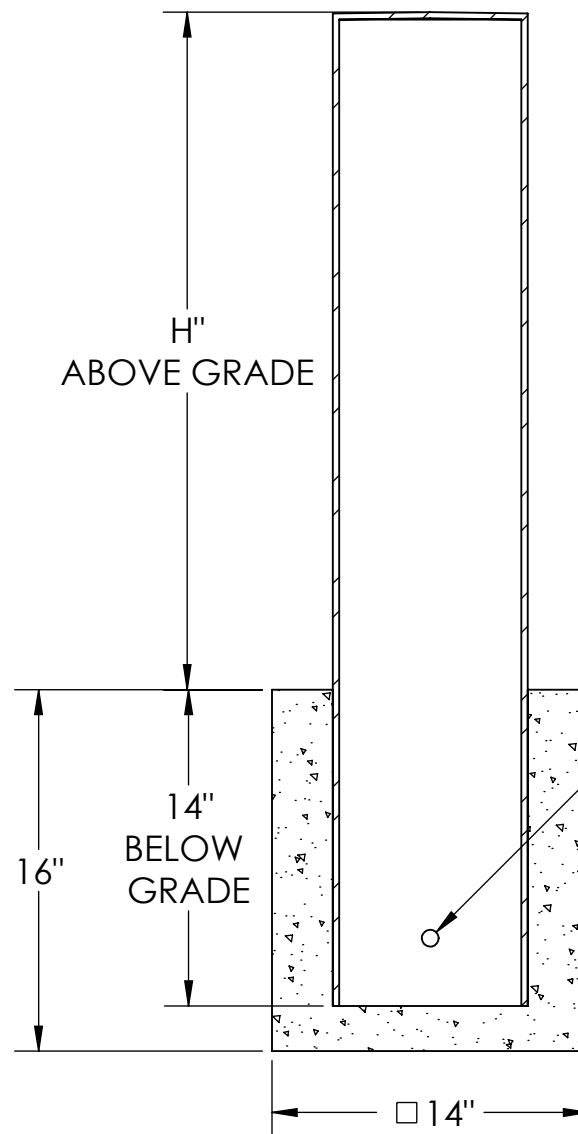
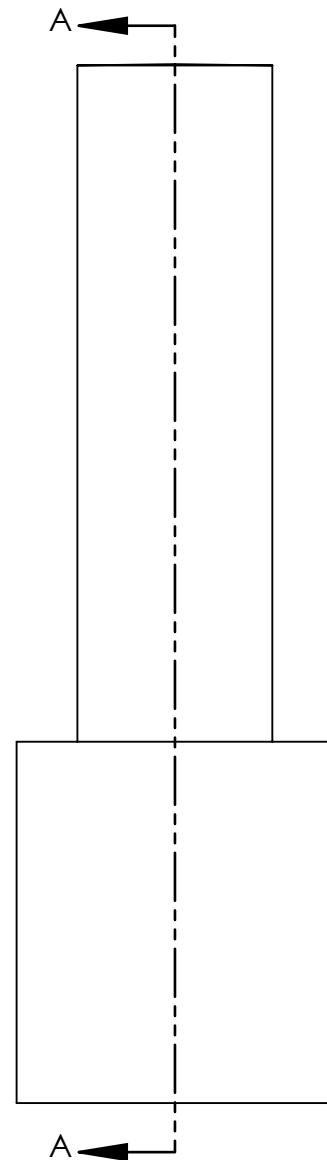
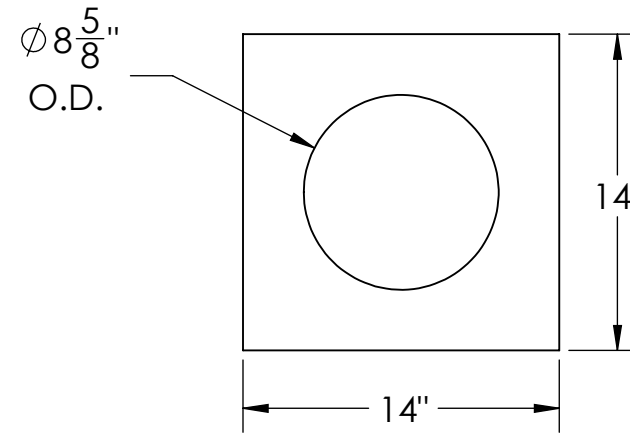

$\phi \frac{3}{4}$ " THRU HOLE
FOR REBAR PASSTHROUGH
(BY OTHERS)

#4 CIRCUMFERENTIAL
BRUSHED FINISH
(SS ONLY)

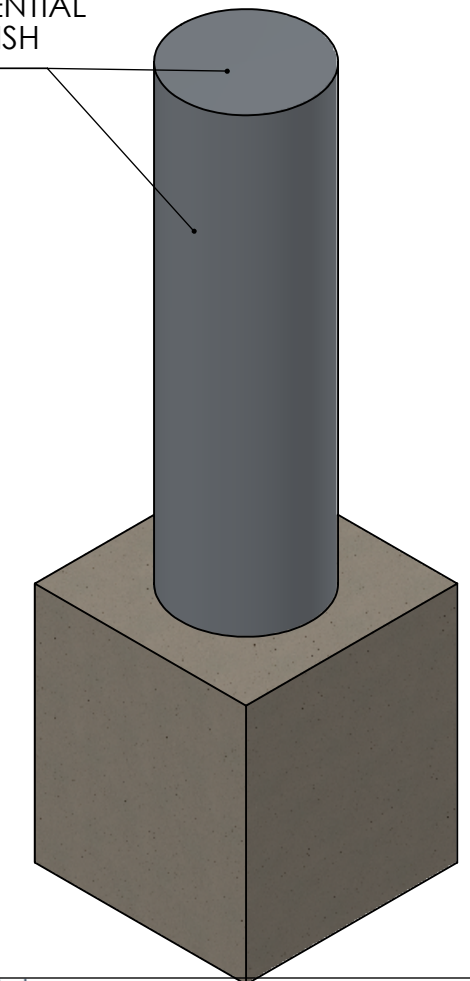

NOTES:

- NON-RATED BOLLARD SHOWN
- FOUNDATION BY OTHERS
- MINIMUM SUGGESTED DIMENSIONS FOR FOUNDATION SHOWN
- FOR CARBON STEEL - ZINC RICH PRIME STANDARD FINISH. GALVANIZE OR POWDERCOAT OPTIONS AVAILABLE
- FOR STAINLESS STEEL - OPTIONAL UPGRADE TO #6 BRUSHED FINISH AVAILABLE

NO MANUAL REVISIONS/CHANGES ALLOWED

	NAME	DATE	 BARRIER DEFENSE SYSTEMS <small>A SHAW STAINLESS COMPANY</small>	986 ROSEDALE DR. HIRAM, GA 30141 (678) 915-2080
DRAWN BY	S.J.	12/18/2019		
CHECKED BY	J.HU.	12/18/2019		
<small>PROPRIETARY AND CONFIDENTIAL THE INFORMATION CONTAINED IN THIS DRAWING IS THE SOLE PROPERTY OF SHAW STAINLESS LLC. ANY REPRODUCTION IN PART OR AS A WHOLE WITHOUT THE WRITTEN PERMISSION OF SHAW STAINLESS LLC IS PROHIBITED.</small>			DESCRIPTION:	8" FLAT TOP FIXED FOUNDATION BOLLARD
REV.	ITEM NO:		SEE SELECTOR	
			SHEET 1 OF 1	



8

7

6

5

4

3

2

1