

8

7

6

5

4

3

2

1

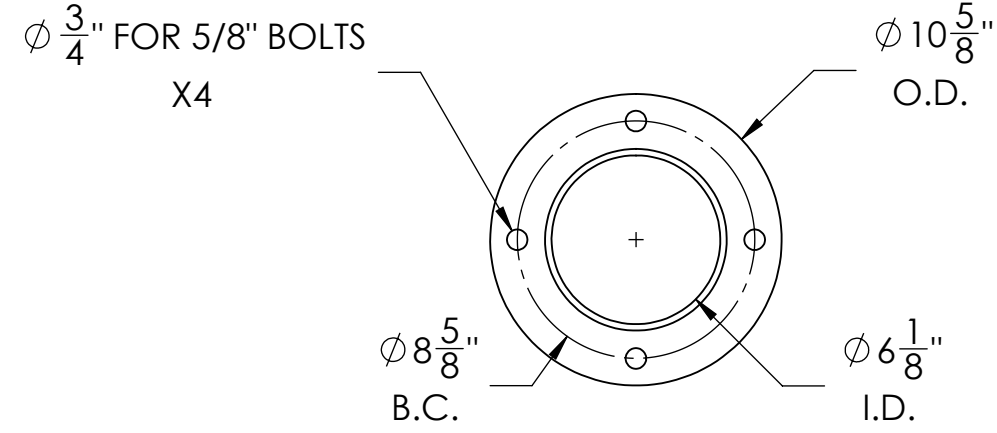
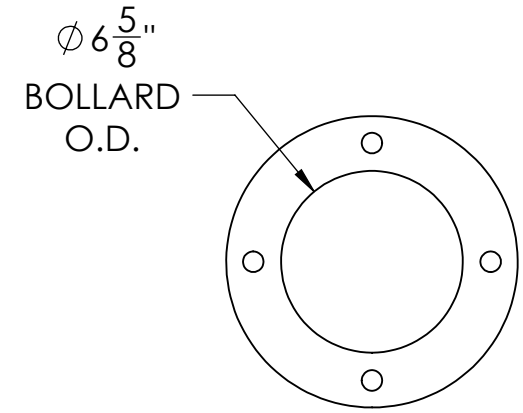

BOLLARD SELECTION			
SELECTION	PART NUMBER	HEIGHT (H)	MATERIAL
	FB4D0636-S	36"	304 SS
	FB4D0642-S	42"	
	FB6D0636-S	36"	316 SS
	FB6D0642-S	42"	
	FBCD0636-S	36"	CARBON STEEL
	FBCD0642-S	42"	

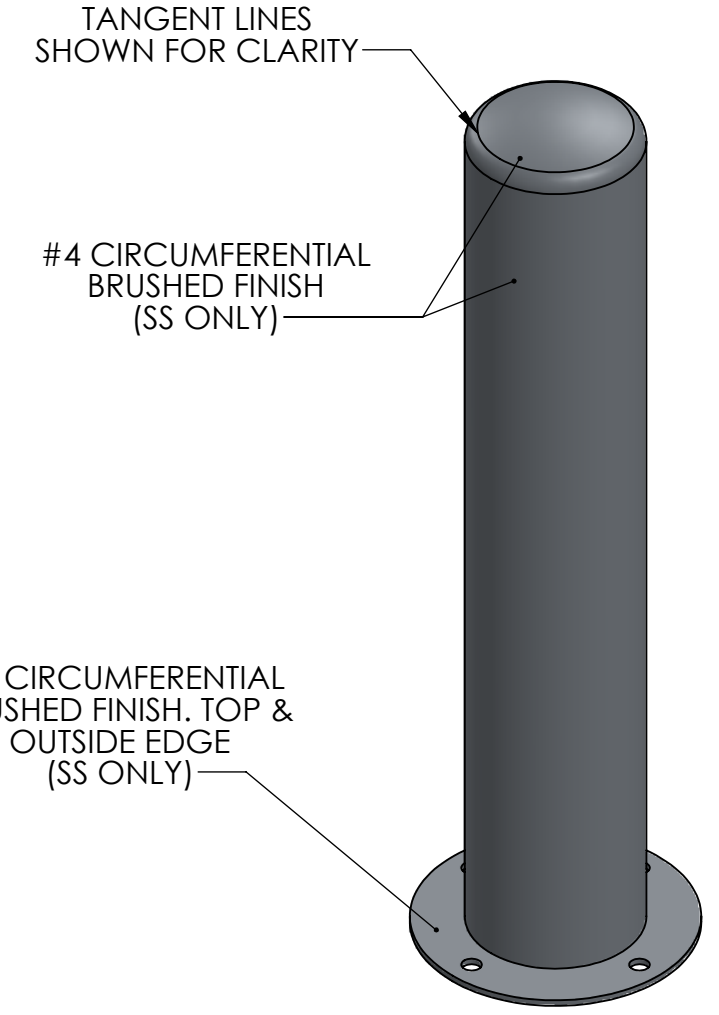
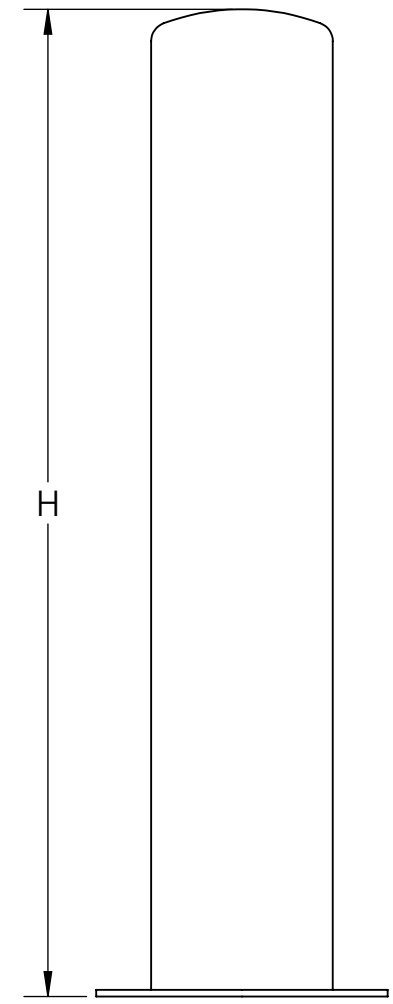

- NOTES:
- NON-RATED BOLLARD SHOWN
 - NO HARDWARE INCLUDED
 - FOR CARBON STEEL - ZINC RICH PRIME STANDARD FINISH. GALVANIZE OR POWDERCOAT OPTIONS AVAILABLE
 - FOR STAINLESS STEEL - OPTIONAL UPGRADE TO #6 BRUSHED FINISH AVAILABLE

	NAME	DATE	<p>986 ROSEDALE DR. HIRAM, GA 30141 (678) 915-2080</p>
DRAWN BY	S.J.	12/18/2019	
CHECKED BY	J.HU.	12/18/2019	DESCRIPTION: 6" DOME TOP SURFACE MOUNT BOLLARD
PROPRIETARY AND CONFIDENTIAL THE INFORMATION CONTAINED IN THIS DRAWING IS THE SOLE PROPERTY OF SHAW STAINLESS LLC. ANY REPRODUCTION IN PART OR AS A WHOLE WITHOUT THE WRITTEN PERMISSION OF SHAW STAINLESS LLC IS PROHIBITED.			REV. ITEM NO: SEE SELECTOR
NO MANUAL REVISIONS/CHANGES ALLOWED			SHEET 1 OF 1

8

7

6

5

4

3

2

1