

8

7

6

5

4

3

2

1

BOLLARD SELECTION

SELECTION	PART NUMBER	ABOVE GRADE HEIGHT (H)	MATERIAL	WEIGHT
	FB4D0630-F	30"	304 SS	72LBS
	FB4D0636-F	36"		82LBS
	FB4D0639-F	39.5"		88LBS
	FB4D0642-F	42"		92LBS
	FB6D0630-F	30"	316L SS	72LBS
	FB6D0636-F	36"		82LBS
	FB6D0639-F	39.5"		88LBS
	FB6D0642-F	42"		92LBS
	FBCD0630-F	30"	CARBON STEEL	70LBS
	FBCD0636-F	36"		80LBS
	FBCD0639-F	39.5"		85LBS
	FBCD0642-F	42"		89LBS

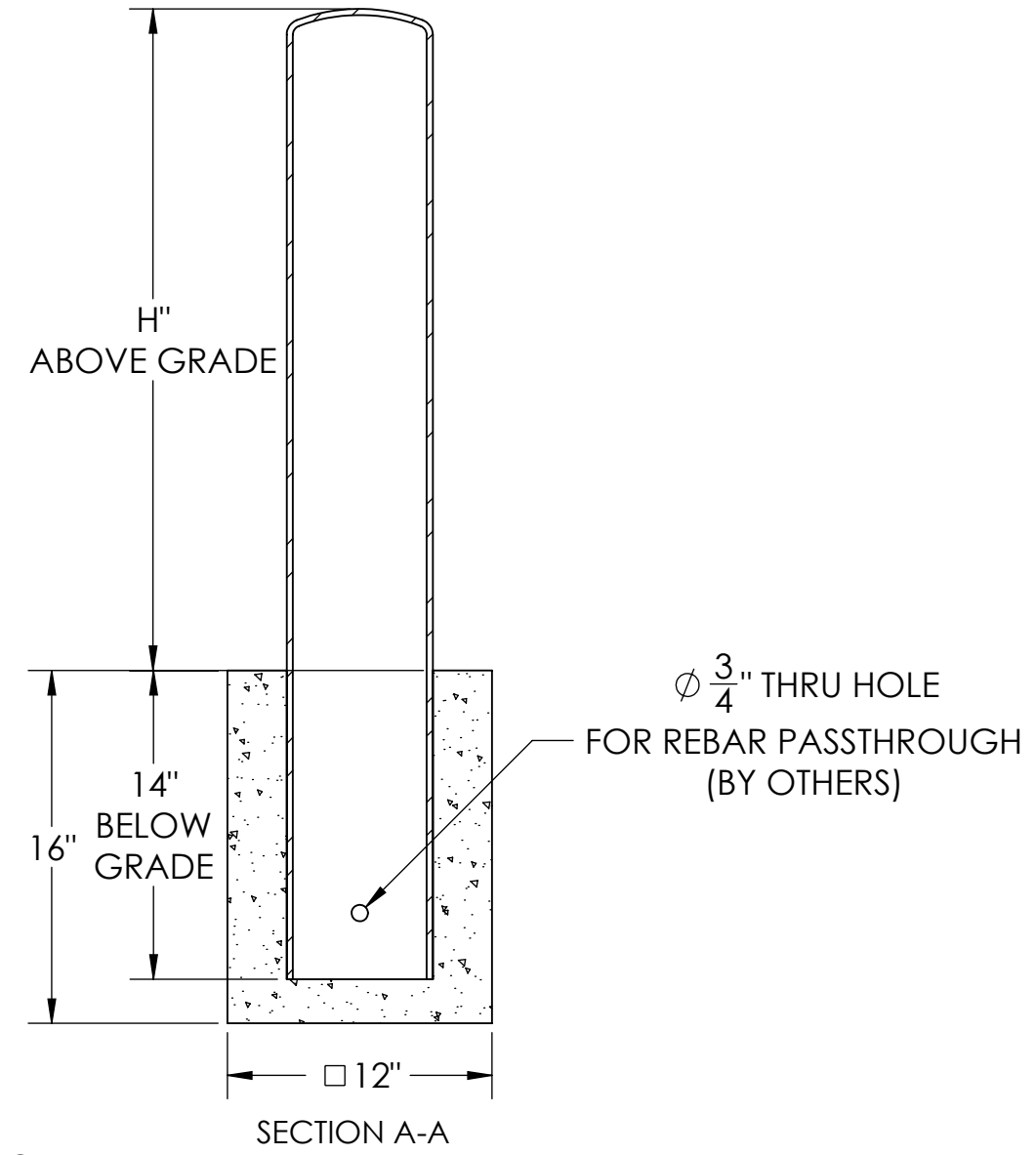
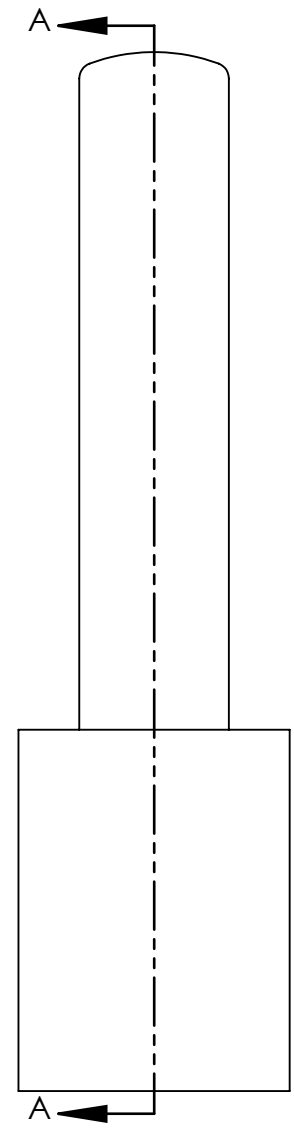
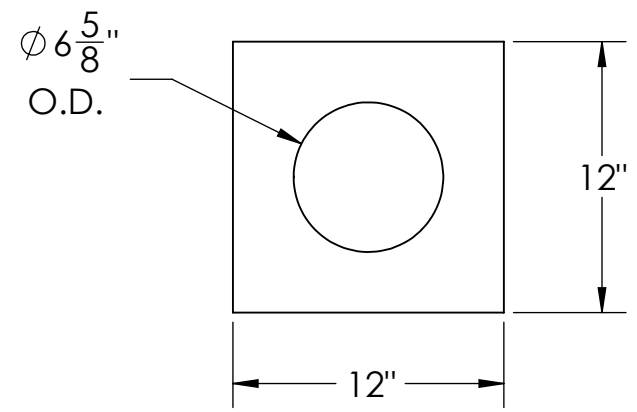

TANGENT LINES SHOWN FOR CLARITY

#4 CIRCUMFERENTIAL BRUSHED FINISH (SS ONLY)

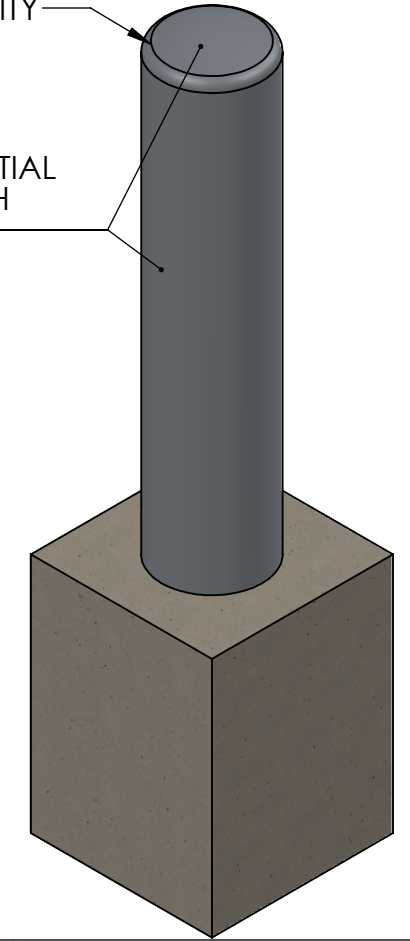

- NOTES:
- NON-RATED BOLLARD SHOWN
 - FOUNDATION BY OTHERS
 - MINIMUM SUGGESTED DIMENSIONS FOR FOUNDATION SHOWN
 - FOR CARBON STEEL - ZINC RICH PRIME STANDARD FINISH. GALVANIZE OR POWDERCOAT OPTIONS AVAILABLE
 - FOR STAINLESS STEEL - OPTIONAL UPGRADE TO #6 BRUSHED FINISH AVAILABLE

	NAME	DATE	<p>986 ROSEDALE DR. HIRAM, GA 30141 (678) 915-2080</p>
DRAWN BY	S.J.	12/18/2019	
CHECKED BY	J.HU.	12/18/2019	
PROPRIETARY AND CONFIDENTIAL THE INFORMATION CONTAINED IN THIS DRAWING IS THE SOLE PROPERTY OF SHAW STAINLESS LLC. ANY REPRODUCTION IN PART OR AS A WHOLE WITHOUT THE WRITTEN PERMISSION OF SHAW STAINLESS LLC IS PROHIBITED.			DESCRIPTION: 6" DOME TOP FIXED FOUNDATION BOLLARD
REV.	ITEM NO:		SEE SELECTOR
			SHEET 1 OF 1



NO MANUAL REVISIONS/CHANGES ALLOWED

8

7

6

5

4

3

2

1