

8

7

6

5

4

3

2

1

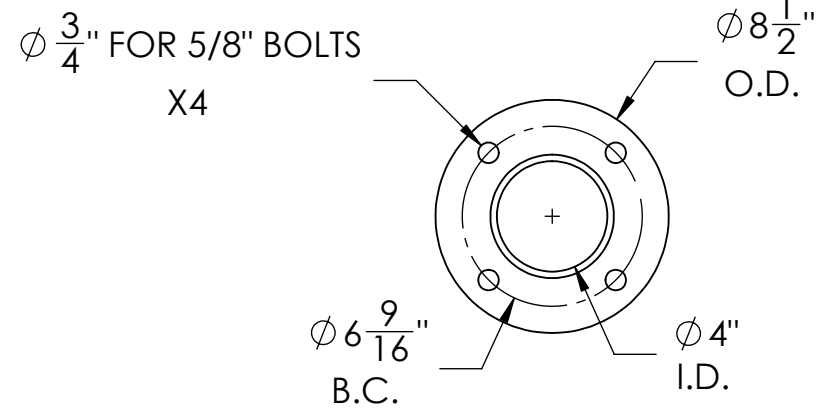
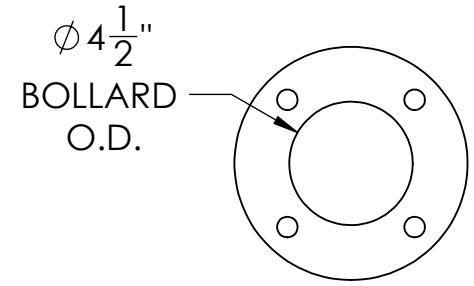

BOLLARD SELECTION				
SELECTION	PART NUMBER	(H)	OVERALL	MATERIAL
	FB4S0436-S	36"	40.63"	304 SS
	FB4S0442-S	42"	46.63"	
	FB6S0436-S	36"	40.63"	316L SS
	FB6S0442-S	42"	46.63"	
	FBCS0436-S	36"	40.63"	CARBON STEEL
	FBCS0442-S	42"	46.63"	

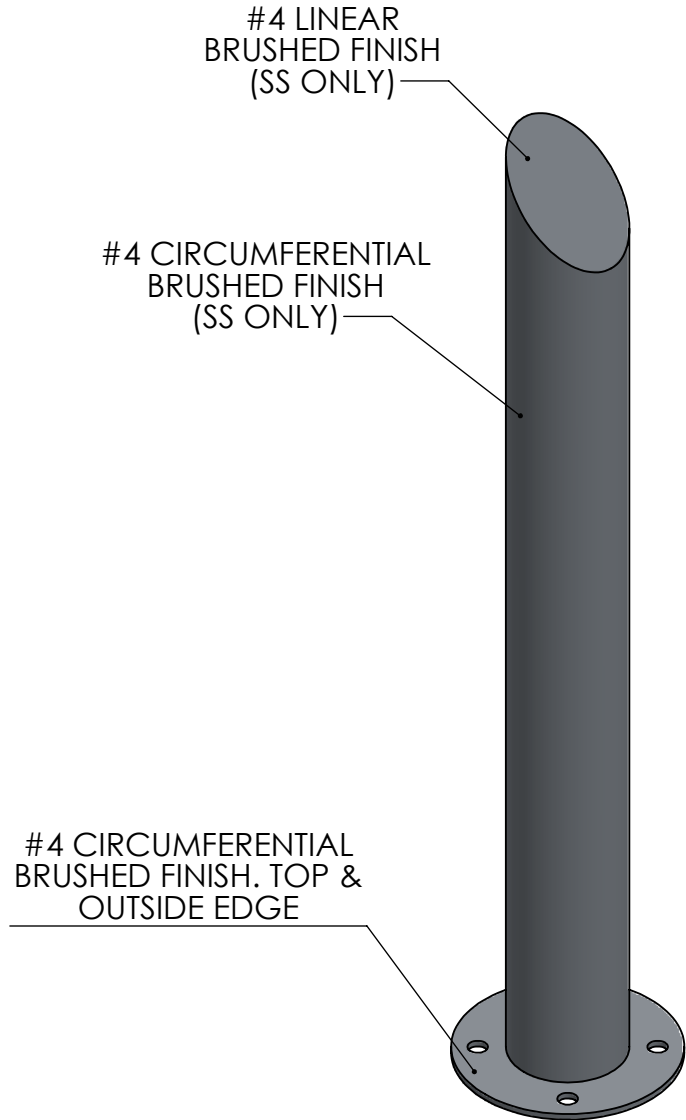
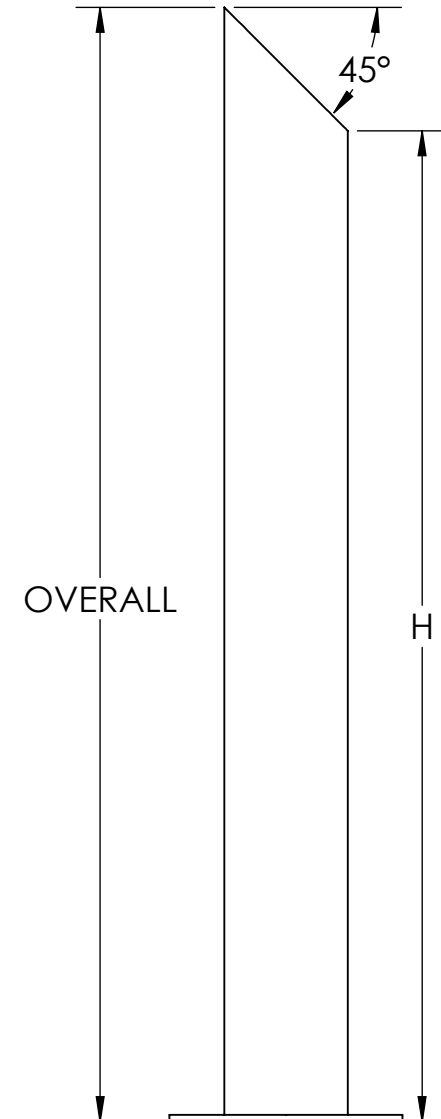

- NOTES:
- NON-RATED BOLLARD SHOWN
 - NO HARDWARE INCLUDED
 - FOR CARBON STEEL - ZINC RICH PRIME STANDARD FINISH. GALVANIZE OR POWDERCOAT OPTIONS AVAILABLE
 - FOR STAINLESS STEEL - OPTIONAL UPGRADE TO #6 BRUSHED FINISH AVAILABLE

	NAME	DATE	BARRIER DEFENSE SYSTEMS <small>A SHAW STAINLESS COMPANY</small>	986 ROSEDALE DR. HIRAM, GA 30141 (678) 915-2080
DRAWN BY	S.J.	12/18/2019		
CHECKED BY	J.HU.	12/18/2019	DESCRIPTION: 4" SLOPE TOP SURFACE MOUNT BOLLARD	
PROPRIETARY AND CONFIDENTIAL THE INFORMATION CONTAINED IN THIS DRAWING IS THE SOLE PROPERTY OF SHAW STAINLESS LLC. ANY REPRODUCTION IN PART OR AS A WHOLE WITHOUT THE WRITTEN PERMISSION OF SHAW STAINLESS LLC IS PROHIBITED.			REV.	ITEM NO: SEE SELECTOR
NO MANUAL REVISIONS/CHANGES ALLOWED			SHEET 1 OF 1	

8

7

6

5

4

3

2

1