

8

7

6

5

4

3

2

1

PROTECTED SIDE

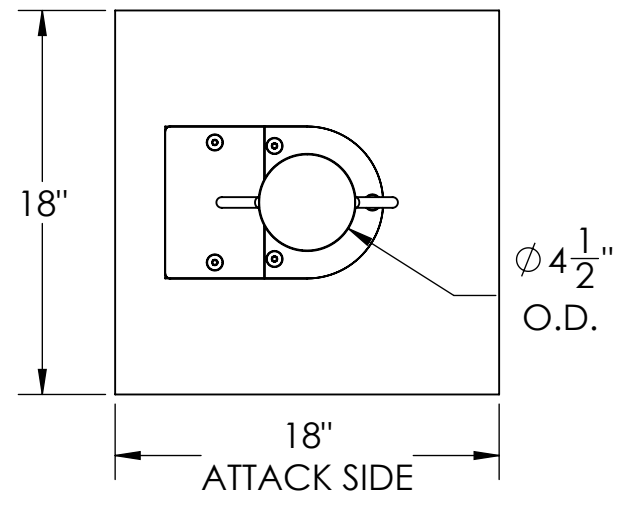

BOLLARD SELECTION

SELECTION	PART NUMBER	ABOVE GRADE HEIGHT (H)	MATERIAL	BOLLARD WEIGHT	HANDLE
	RB4F0430	30"	304 SS	39LBS	
	RB4F0436	36"		44LBS	
	RB4F0440	40"		48LBS	
	RB6F0430	30"	316L SS	39LBS	
	RB6F0436	36"		44LBS	
	RB6F0440	40"		48LBS	
	RBCF0430	29.5"	CARBON STEEL	39LBS	
	RBCF0436	35.5"		43LBS	
	RBCF0440	39.5"		47LBS	

D

D

C

C

B

B

A

A

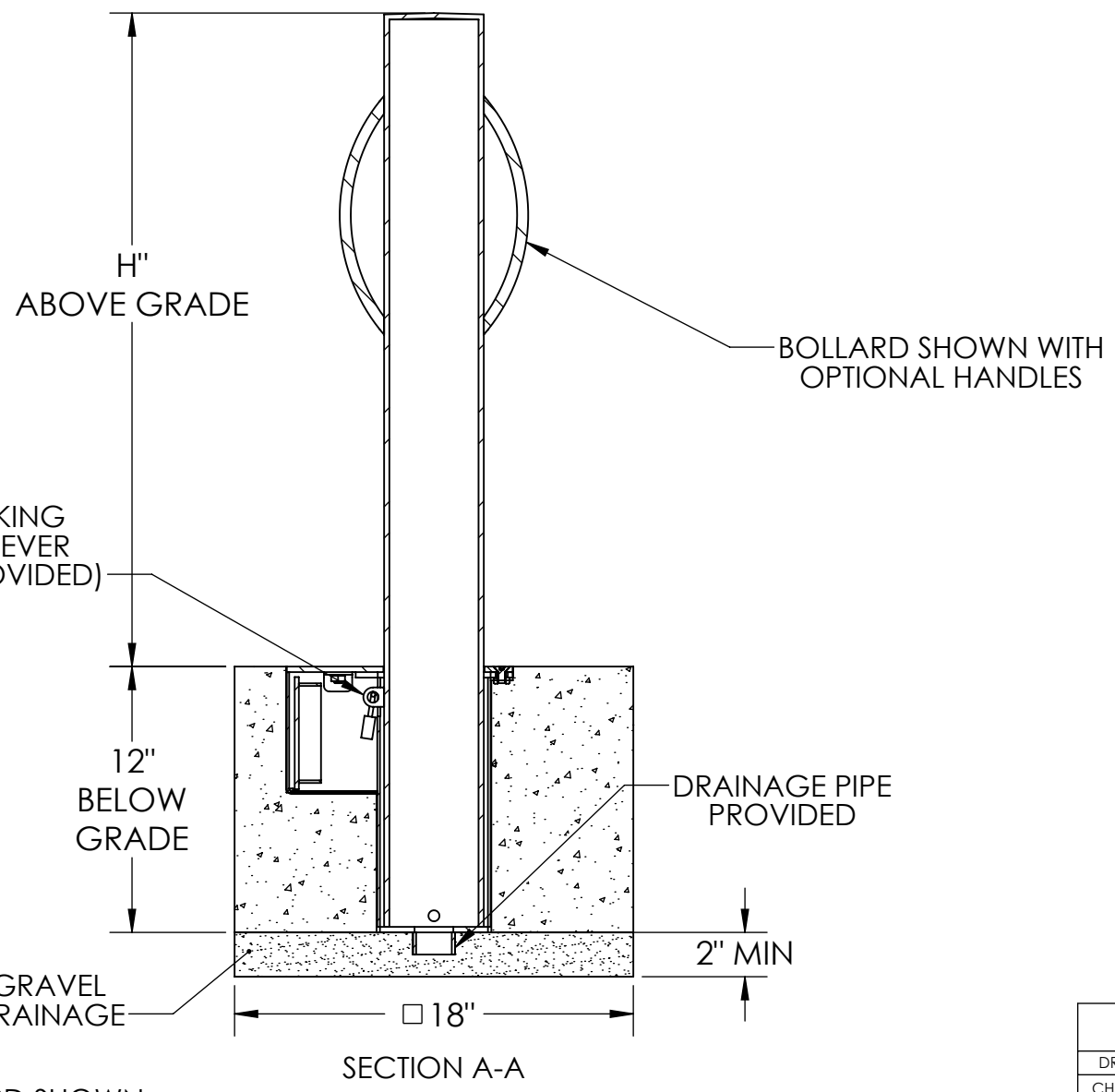
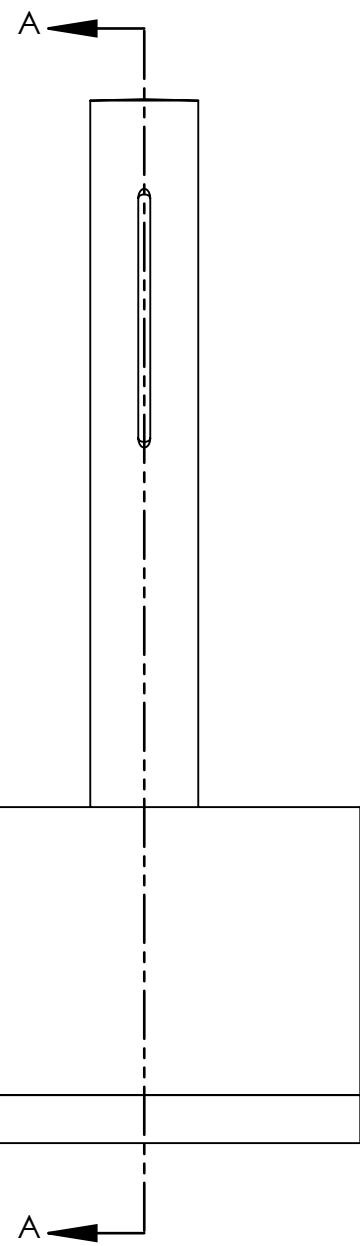

#4 CIRCUMFERENTIAL BRUSHED FINISH (SS ONLY)

#4 LINEAR BRUSHED FINISH (SS ONLY)

VACUANCY COVER STORAGE

BOLLARD SHOWN WITH OPTIONAL HANDLES

OPTION FOR LOCKING BOLLARD TO RECIEVER (PADLOCK NOT PROVIDED)

DRAINAGE PIPE PROVIDED

GRAVEL DRAINAGE

SECTION A-A

- NOTES:
- NON-RATED BOLLARD SHOWN
 - FOUNDATION BY OTHERS
 - MINIMUM SUGGESTED DIMENSIONS FOR FOUNDATION SHOWN
 - FOR CARBON STEEL - ZINC RICH PRIME STANDARD FINISH. GALVANIZE OR POWDERCOAT OPTIONS AVAILABLE
 - FOR STAINLESS STEEL - OPTIONAL UPGRADE TO #6 BRUSHED FINISH AVAILABLE



	NAME	DATE	 BARRIER DEFENSE SYSTEMS <small>A SHAW STAINLESS COMPANY</small>	986 ROSEDALE DR. HIRAM, GA 30141 (678) 915-2080
DRAWN BY	S.J.	2/19/2020		
CHECKED BY	J.HU.	2/19/2020	DESCRIPTION: 4" FLAT TOP REMOVABLE BOLLARD W/ RCVR	
PROPRIETARY AND CONFIDENTIAL THE INFORMATION CONTAINED IN THIS DRAWING IS THE SOLE PROPERTY OF SHAW STAINLESS LLC. ANY REPRODUCTION IN PART OR AS A WHOLE WITHOUT THE WRITTEN PERMISSION OF SHAW STAINLESS LLC IS PROHIBITED.			REV.	ITEM NO: SEE SELECTOR
NO MANUAL REVISIONS/CHANGES ALLOWED			SHEET 1 OF 1	

8

7

6

5

4

3

2

1